

K35

Specifications 1/5

- Incremental Type (Hollow shaft, blind hole)
 - Feature: small, logical compact configuration, Various output mode and different shaft available
 - Application: Automation Control for serve motor、 textile industry、 packing machinery、 small instrument , etc.
 - External dimensions: external diameter Ø35mm, thickness 35mm, shaft Ø6mm; Ø8mm; Ø10mm (depth 15mm)
 - Resolution: up to 5000P/R
 - Supply voltage: DC5V; DC8-30V
 - Protection: IP50
 - Cable length: 500mm
 - Weight: about 100g

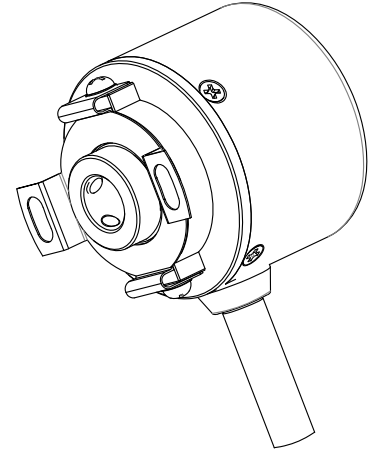

Model Guide

- Model form (filled required parameters in the box as following)

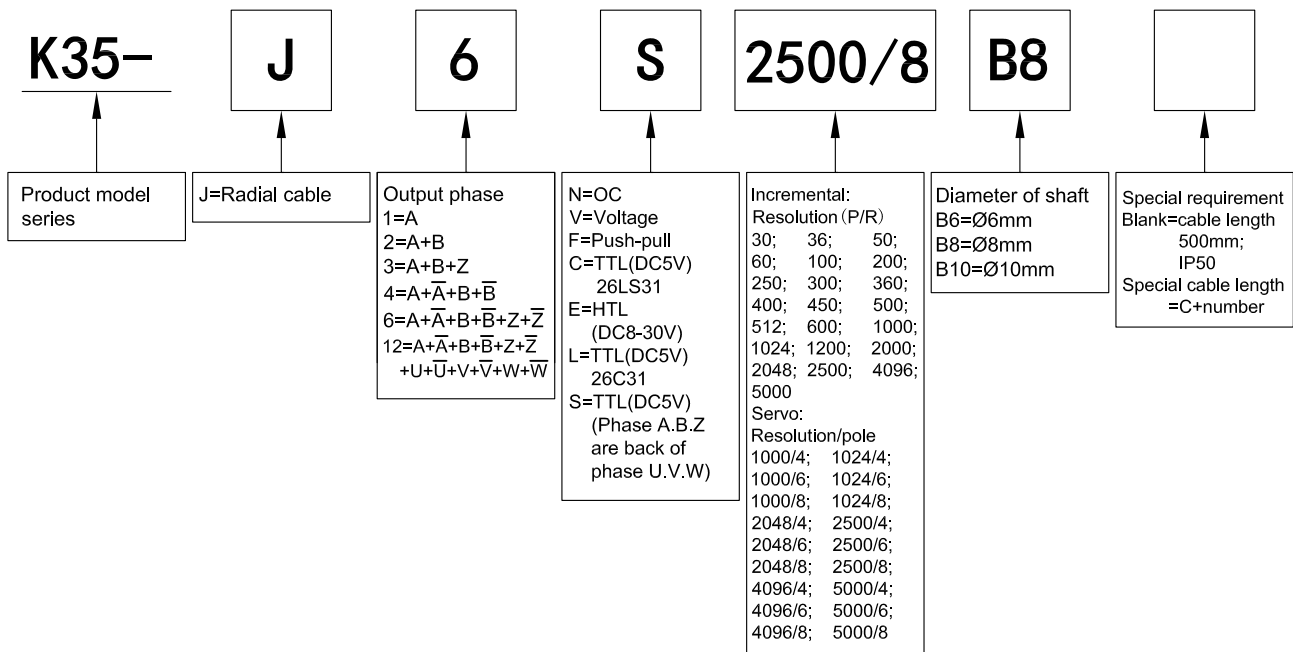

- Must choose supply voltage: DC5V; DC8-30V
- Must choose leaf spring 35T29; 35T40 (Please refer to specifications 5/5)

K35 Specifications 2/5

Output Mode

Output type	Output circuit	Output wave form	Connection
OC		<p> $a.b.c.d = \frac{T}{4} \pm \frac{T}{8}$ Phase A is ahead of B by $\frac{T}{4} \pm \frac{T}{8}$, rotate direction CW (View from shaft end, direction is clockwise rotation) CW direction \rightarrow </p>	0=GND 1=red=DC5V; DC8-30V 2=black=OV 3=white=A 4=green=B 5=yellow=Z
Push-Pull		<p> $a.b.c.d = \frac{T}{4} \pm \frac{T}{8}$ Phase A is ahead of B by $\frac{T}{4} \pm \frac{T}{8}$, rotate direction CW (View from shaft end, direction is clockwise rotation) CW direction \rightarrow </p>	
Voltage		<p> $a.b.c.d = \frac{T}{4} \pm \frac{T}{8}$ Phase A is ahead of B by $\frac{T}{4} \pm \frac{T}{8}$, rotate direction CW (View from shaft end, direction is clockwise rotation) CW direction \rightarrow </p>	
TTL HTL		<p> $a.b.c.d = \frac{T}{4} \pm \frac{T}{8}$ Phase A is ahead of B by $\frac{T}{4} \pm \frac{T}{8}$, rotate direction CW (View from shaft end, direction is clockwise rotation) CW direction \rightarrow </p>	

K35 Specifications 3/5

● Output Mode

Output type	Output circuit	Output wave form	Connection																																																																	
TTL			<p>0=shielding=GND 1=red=DC5V 2=black=OV 3=white=A 4=green=B 5=yellow=Z 6=white/black=\bar{A} 7=green/black=\bar{B} 8=yellow/black=\bar{Z} 9=blue=U 10=grey=V 11=pink=W 12=blue/black=\bar{U} 13=grey/black=\bar{V} 14=pink/black=\bar{W}</p>																																																																	
TTL (phase A.B.Z are back of phase U.V.W)	<table border="1" style="margin: 10px auto;"> <thead> <tr> <th>pole</th> <th>g,h,j,k,m,n</th> <th>r</th> </tr> </thead> <tbody> <tr> <td>4</td> <td>$30 \pm 1^\circ$</td> <td>180°</td> </tr> <tr> <td>6</td> <td>$20 \pm 1^\circ$</td> <td>120°</td> </tr> <tr> <td>8</td> <td>$15 \pm 1^\circ$</td> <td>90°</td> </tr> </tbody> </table>	pole	g,h,j,k,m,n	r	4	$30 \pm 1^\circ$	180°	6	$20 \pm 1^\circ$	120°	8	$15 \pm 1^\circ$	90°		<table border="1" style="width: 100%; border-collapse: collapse;"> <thead> <tr> <th rowspan="2">No.</th> <th rowspan="2">Function Color</th> <th colspan="3">Mode</th> </tr> <tr> <th>1</th> <th>2</th> <th>3</th> </tr> </thead> <tbody> <tr> <td>3</td> <td>white</td> <td>HZ</td> <td>U</td> <td>A</td> </tr> <tr> <td>6</td> <td>white/black</td> <td>HZ</td> <td>\bar{U}</td> <td>\bar{A}</td> </tr> <tr> <td>4</td> <td>green</td> <td>HZ</td> <td>V</td> <td>B</td> </tr> <tr> <td>7</td> <td>green/black</td> <td>HZ</td> <td>\bar{V}</td> <td>\bar{B}</td> </tr> <tr> <td>5</td> <td>yellow</td> <td>HZ</td> <td>W</td> <td>Z</td> </tr> <tr> <td>8</td> <td>yellow/black</td> <td>HZ</td> <td>\bar{W}</td> <td>\bar{Z}</td> </tr> <tr> <td>1</td> <td>red</td> <td colspan="3">DC+5V</td> </tr> <tr> <td>2</td> <td>black</td> <td colspan="3">OV</td> </tr> <tr> <td>0</td> <td>shielding</td> <td colspan="3">GND</td> </tr> </tbody> </table>	No.	Function Color	Mode			1	2	3	3	white	HZ	U	A	6	white/black	HZ	\bar{U}	\bar{A}	4	green	HZ	V	B	7	green/black	HZ	\bar{V}	\bar{B}	5	yellow	HZ	W	Z	8	yellow/black	HZ	\bar{W}	\bar{Z}	1	red	DC+5V			2	black	OV			0	shielding	GND		
pole	g,h,j,k,m,n	r																																																																		
4	$30 \pm 1^\circ$	180°																																																																		
6	$20 \pm 1^\circ$	120°																																																																		
8	$15 \pm 1^\circ$	90°																																																																		
No.	Function Color	Mode																																																																		
		1	2	3																																																																
3	white	HZ	U	A																																																																
6	white/black	HZ	\bar{U}	\bar{A}																																																																
4	green	HZ	V	B																																																																
7	green/black	HZ	\bar{V}	\bar{B}																																																																
5	yellow	HZ	W	Z																																																																
8	yellow/black	HZ	\bar{W}	\bar{Z}																																																																
1	red	DC+5V																																																																		
2	black	OV																																																																		
0	shielding	GND																																																																		
<p>Timing Chart</p>																																																																				
<p>Symbol signification</p> <ul style="list-style-type: none"> ★: indicate position of UVW channel ☆: position to start counting ABZ channel ▨: non-using zone HZ: high impedance 																																																																				

■ Electrical Characteristics

Parameter Item	Output type	OC		Voltage		Push-pull		TTL(26LS31)	TTL(26C31)	TTL(26C31) (Phase A,B,Z are back of phase U,V,W)	HTL(HD7)
		Supply voltage		DC+5V±5% & DC8V-30V±5%						DC+5V±5%	
Consumption current		100mA Max						120mA Max			
Allowable ripple		≤3%rms									
Top response frequency		100KHz						200KHz		300KHz	
Output volume	Output current	Input	≤30mA	Load resistance 2.2K	≤30mA	≤±20mA		≤±50mA			
		Output	—		≤10mA						
	Output voltage	"H"	—	—	≥[(Supply voltage) -2.5V]	≥2.5V		≥V _{cc} -3 V _{DC}			
		"L"	≤0.4V	≤0.7V(less than 20mA)	≤0.4V(30mA)	≤0.5V		≤ 1V V _{DC}			
Load voltage	≤DC30V		—		—						
Rise & Fall time		Less than 2us(cable length: 2m)						Less than 1us(Cable length: 2m)		≤100ns	
Insulation strength		AC500V 60s									
Insulation resistance		10MΩ									
Mark to space ratio		45% to 55%									
Phase shift between A & B		90°±10° (low speed,frequency ≤1000Hz)									
		90°±20° (high speed,frequency >1000Hz)									
Origin motion		Low level available	High level available	Low level available	—		Low level available	—			
Delay motion time *		—						510±220ms		—	
GND		not connect to encoder									

* Phase A,B,Z are back of phase U,V,W when power on.

■ Mechanical Characteristics

Shaft	Ø6mm; Ø8mm; Ø10mm(optional)
Starting torque	Less than $5.9 \times 10^{-3} \text{N} \cdot \text{m}$
Inertia moment	Less than $1 \times 10^{-6} \text{kg} \cdot \text{m}^2$
Shaft load	Radial 30N; Axial 20N
Slew speed	≤5000 rpm
Bearing Life	1.5×10^9 revs at rated load(100000hrs at 2500RPM)
Shell	Die cast aluminum
Weight	about 100g

■ Environmental Specifications

Environmental temperature	Operating: -20~+85°C(repeatable winding cable: -10°C); Storage: -25~+90°C
Environmental humidity	Operating and storage: 35~85%RH(noncondensing)
Vibration(endure)	Amplitude 0.75mm,5~55Hz,2h for X,Y,Z direction individually
Shock(endure)	490m/s ² 11ms three times for X,Y,Z direction individually
Protection	IP50

K35 Specifications 5/5

Basic Dimensions

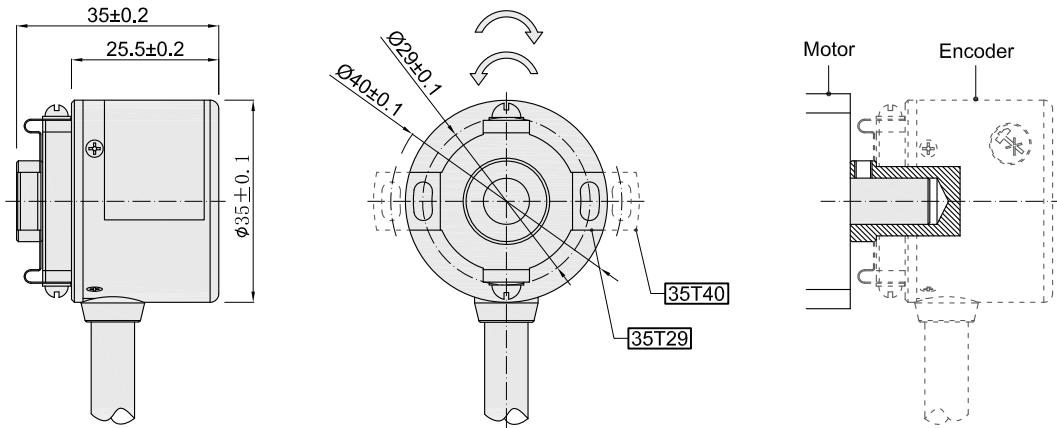

Assembling requirement

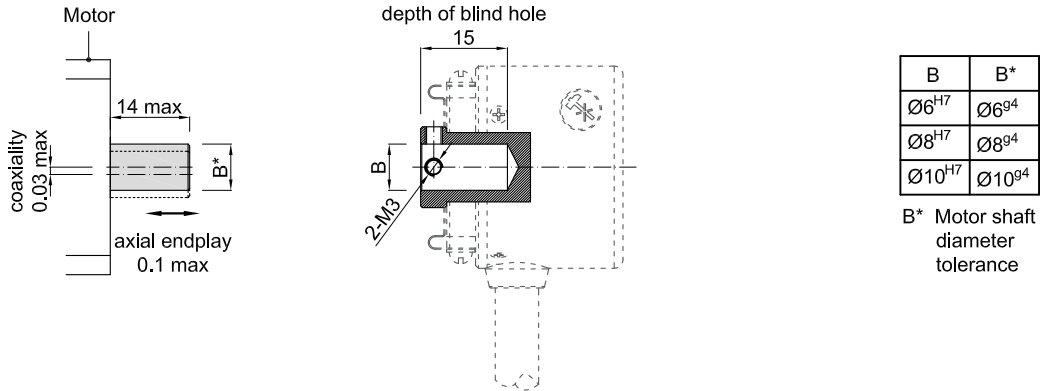

Leaf spring

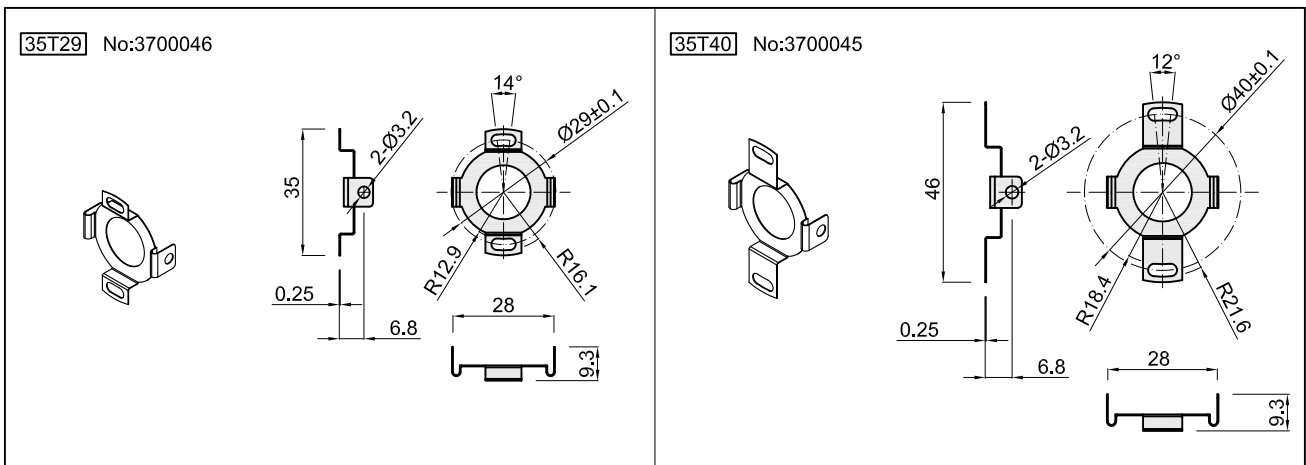

Unit: mm

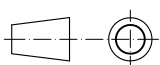

= Rotate direction of incremental signal output shaft

= Rotate direction of servo signal output shaft

About vibration

Vibration act on encoder always cause wrong pulse , so we should pay attention to working place. More pulse per revolution , narrower groovy spacing of grating , more effect to encoder by vibration, when rev is low or stop , vibration act on shaft or main body would cause grating vibrating , so encoder might make wrong pulse.